



Vertical Storage Tanks • Horizontal Transport Tanks
Nurse Trailers • Cone Bottom Trailers • Tender Tank Trailers



DESIGNED BETTER. BUILT STRONGER. LASTS LONGER.



THIS IS ENDURAPLAS



Superior Liquid Management Equipment

At Enduraplas we specialize in manufacturing products that help you manage your liquid better. Our large range of liquid storage tanks, tank trailers, spray equipment and water storage solutions are built to last much longer than the industry norm. Using decades of development and research, exceptional design, experience and a relentless passion to innovate, we've made products with your application in mind. Simply put: We know what works.



Built in America. Built to Perform.

Enduraplas products are proudly built in the United States from premium components like quality polyethylene. This guarantees unmatched durability that has consistently outperformed. Since 2003 our liquid management tanks have been built with thicker walls and superior poly materials. Rigorously testing America's strongest tanks has ensured long-lasting durability. Engineered for Endurance® is not just a statement, it's a reality.



CONTENTS

- 6 Flat Bottom Storage Tanks
- 12 Cone Bottom Storage Tanks
- 18 Freestanding Transport Tanks
- 24 Sump Bottom Transport Tanks
- 29 Pickup Tanks
- 32 Nurse Trailers
- 38 Cone Bottom Trailers
- 42 Tender Tank Trailers
- 44 Accessories & Parts

Our Vision:

To be the trusted resource for superior liquid management equipment when and where you need it.

ENDURAPLAS ADVANTAGE

ENGINEERED FOR ENDURANCE®

At Enduraplas the success of our products is measured not at one particular moment but at every step throughout the life of the product. To produce something exceptional means to be exceptional in all aspects from conception to creation to implementation and beyond.

The Enduraplas Advantage speaks to the quality and integrity that pervades every step of the product development process. At every phase of development, Enduraplas stands out from the competition. Our products are designed with a higher level of attention to engineered excellence. They are produced with higher quality parts and components. And they last longer in real world applications, where it matters most, which means less downtime, less money spent on repairs, and greater productivity. **We call it the Endruaplas Advantage.**

The message is simple but profound. An advantage isn't something that just happens, but rather it is something that is created through a higher attention to detail and a greater investment in value. Enduraplas Advantage begins with an idea and ends with a product that outperforms and outlasts the competition.



[DESIGNED BETTER.]



[BUILT STRONGER.]



[LASTS LONGER.]

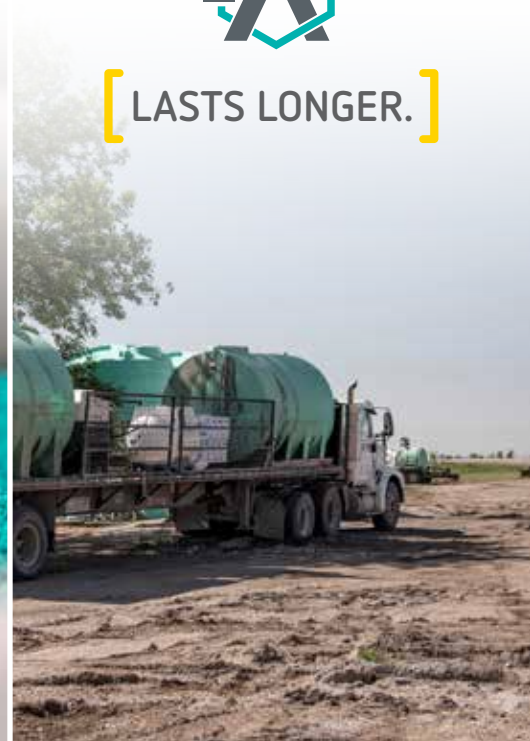
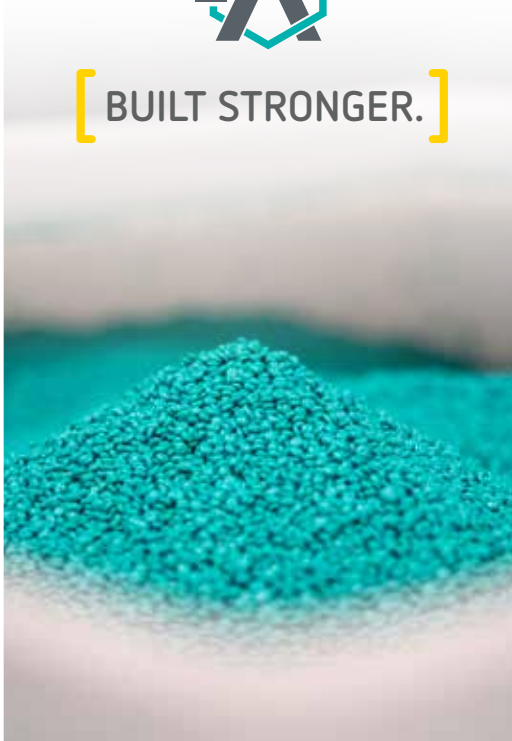
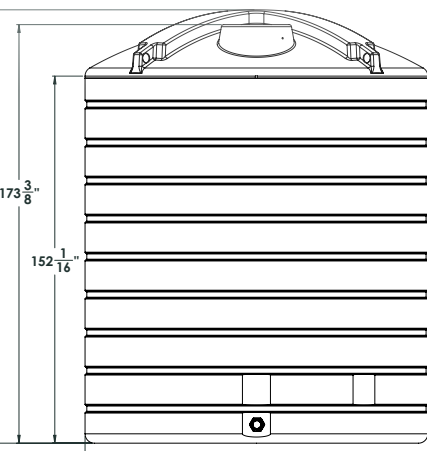

TRAINING

READ OR WATCH HELPFUL TIPS & HOW-TO'S



SOME TOPICS WE COVER

Buying a Nurse or Cone Bottom Trailer

Storing Liquid Fertilizer

Installing a Vertical Storage Tank

Setting Up a Tender Tank Trailer

Buying a Horizontal Leg Tank



Visit: www.LiquidStorageTraining.com

FLAT BOTTOM STORAGE TANKS



Featured Image: 10,000 Gallon Flat Bottom Storage Tanks (THV10000)

THV SERIES



Featured Image: 6,000 Gallon Flat Bottom Storage Tanks (THV06000)

ENDURAPLAS ADVANTAGE

STRONG-X™ ROOF DESIGN

The beefed-up roof structure with molded-in truss-like supports eliminates collapsing in extreme weather conditions.

RIBBED-WALL™ STRUCTURE

The ribs act like belts around the tank keeping it in shape. This reduces bulging.

THICK-WALL™ DESIGN

Extra-thick walls provide unmatched strength and durability.

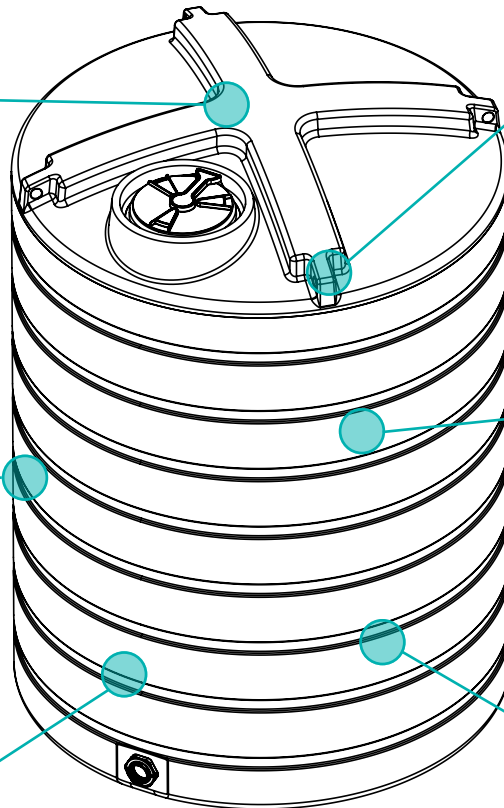

ANCHOR-POINT™ LUGS

Four hefty built-in lifting and tie-down points at each corner make it easy to handle.

ROTO-MOLD CONSTRUCTION

When cooked and cooled at an even rate, the raw material is bonded together to make this tank virtually indestructible.

SINGLE-PIECE™ CONSTRUCTION

Rotationally-molded in a single mold means the tank is seamless, water-tight and leak-proof.

THV SERIES SPECS - LARGE TANKS

	PRODUCT CODE	TANK SIZE (GAL)	DIAMETER	HEIGHT	LID SIZE	FITTING SIZE	SPECIFIC GRAVITY	TIE DOWN POINTS	SIPHON TUBE INCLUDED	WARRANTY	COLORS**	MANUFACTURED IN*
THV SERIES												
BEST SELLER	1	THV10000	10,400	144"	178"	16"	3"	1.9	Yes	Yes	*10 Years	Green, Black ND, TX
	2	THV08000	8,150	144"	142"	16"	3"	1.9	Yes	Yes	*10 Years	Green, Black ND, TX
	3	THV07011	7,011	144"	126"	16"	3"	1.9	Yes	Yes	*10 Years	Green, Black ND, TX
	4	THV06250	6,300	120"	147"	16"	3"	1.9	Yes	Yes	*10 Years	Green, Black TX
	5	THV06011	6,011	144"	110"	16"	3"	1.9	Yes	Yes	*10 Years	Green, Black ND, TX
	6	THV06000	6,500	110"	179"	16"	3"	1.9	Yes	Yes	*10 Years	Green, Black ND
	7	THV05050	5,050	120"	120"	16"	3"	1.9	Yes	Yes	*10 Years	Green, Black TX
	8	THV05200	5,200	100"	164"	16"	3"	1.9	Yes	Yes	*10 Years	Green, Black TX
BEST SELLER	9	THV05000	5,500	110"	150"	16"	3"	1.9	Yes	Yes	*10 Years	Green, Black ND

**Yellow & White are available upon special request
*ND = North Dakota, TX = Texas

*Warranty must be registered to receive 10 years. See page 51 for details.

Featured Image: 10,000 Gallon Flat Bottom Storage Tanks (THV10000)

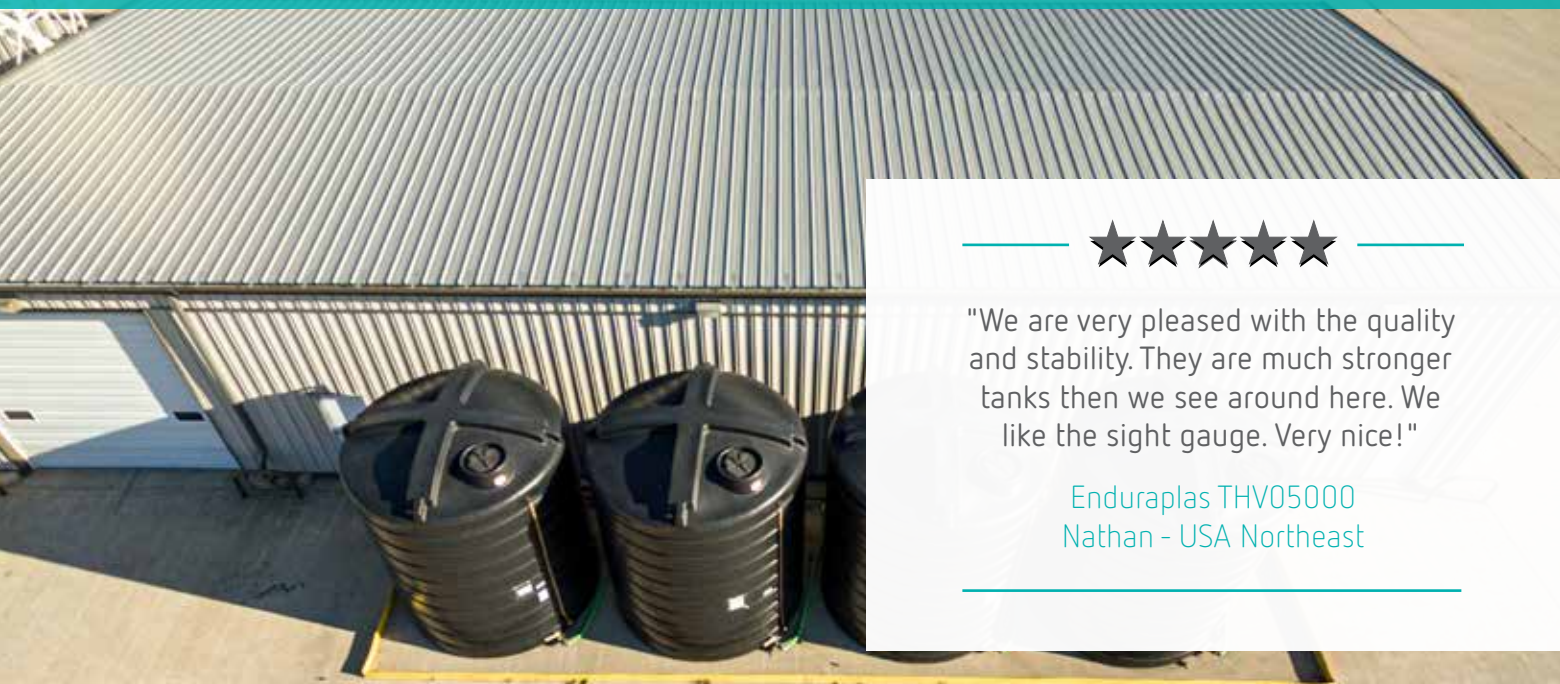

"We are very pleased with the quality and stability. They are much stronger tanks than we see around here. We like the sight gauge. Very nice!"

Enduraplas THV05000
Nathan - USA Northeast

THV SERIES SPECS - SMALL TANKS

	PRODUCT CODE	TANK SIZE (GAL)	DIAMETER	HEIGHT	LID SIZE	FITTING SIZE	SPECIFIC GRAVITY	TIE DOWN POINTS	SIPHON TUBE INCLUDED	WARRANTY	COLORS**	MANUFACTURED IN*
	THV SERIES											
	10	THV04000	4,100	110"	124"	16"	3"	1.9	Yes	Yes	*10 Years	Green, Black ND
	11	THV03200	3,300	110"	103"	16"	3"	1.9	Yes	Yes	*10 Years	Green, Black ND
	12	THV03100	3,100	100"	103"	16"	3"	1.9	Yes	Yes	*10 Years	Green, Black TX
BEST SELLER	13	THV03000	3,126	90"	125"	16"	3"	1.9	Yes	Yes	*10 Years	Green, Black ND, TX
	14	THV02600	2,700	100"	92"	16"	2"	1.9	Yes	No	*10 Years	Green, Black TX
	15	THV02520	2,600	110"	86"	16"	2"	1.9	Yes	No	*10 Years	Green, Black ND
BEST SELLER	16	THV02500	2,680	90"	113"	16"	2"	1.9	Yes	No	*10 Years	Green, Black ND, TX
	17	THV02100	2,208	85"	100"	16"	2"	1.9	Yes	No	*10 Years	Green, Black ND, TX
	18	THV02020	2,100	110"	73"	16"	2"	1.9	Yes	No	*10 Years	Green, Black ND
	19	THV02000	2,276	90"	93"	16"	2"	1.9	Yes	No	*10 Years	Green, Black ND, TX
BEST SELLER	20	THV01750	2,009	85"	89"	16"	2"	1.9	Yes	No	*10 Years	Green, Black ND, TX
	21	THV01650	1,731	90"	75"	16"	2"	1.9	Yes	No	*10 Years	Green, Black ND, TX
BEST SELLER	22	THV01550	1,700	85"	80"	16"	2"	1.9	Yes	No	*10 Years	Green, Black ND, TX
	23	THV01400	1,450	80"	79"	16"	2"	1.9	Yes	No	*10 Years	Green, Black ND
	24	THV01350	1,530	85"	71"	16"	2"	1.9	Yes	No	*10 Years	Green, Black ND, TX
	25	THV01125	1,125	85"	56"	16"	2"	1.9	Yes	No	*10 Years	Green, Black TX
	26	THV01100	1,100	60"	97"	16"	2"	1.9	Yes	No	*10 Years	Green, Black ND, TX
	27	THV01000	1,125	80"	65"	16"	2"	1.9	Yes	No	*10 Years	Green, Black ND
	28	THV00870	870	60"	78"	16"	2"	1.9	Yes	No	*10 Years	Green, Black ND, TX
	29	THV00600	600	40"	120"	16"	2"	1.9	Yes	No	*10 Years	Green, Black TX
	30	THV00550	550	60"	52"	16"	2"	1.9	Yes	No	*10 Years	Green, Black ND, TX
	31	THV00340	340	40"	74"	16"	2"	1.9	Yes	No	*10 Years	Green, Black TX
	32	THV00210	210	40"	48"	16"	2"	1.9	Yes	No	*10 Years	Green, Black TX
	33	THV00200	200	30"	79"	8"	2"	1.9	Yes	No	*10 Years	Green, Black TX
	34	THV00150	150	30"	61"	8"	2"	1.9	Yes	No	*10 Years	Green, Black TX
	35	THV00100	100	30"	43"	8"	2"	1.9	Yes	No	*10 Years	Green, Black TX

**Yellow & White are available upon special request
*ND = North Dakota, TX = Texas

*Warranty must be registered to receive 10 years. See page 51 for details.



THV SERIES



BEST SELLER

*Manufactured in ND & TX

THV10000

Capacity	10,400 Gallons
Dimensions	144"D x 178"H
Specs	Page 8, Row 1



BEST SELLER

*Manufactured in ND

THV05000

Capacity	5,500 Gallons
Dimensions	110"D x 150"H
Specs	Page 8, Row 9



BEST SELLER

*Manufactured in ND & TX

THV03000

Capacity	3,126 Gallons
Dimensions	90"D x 125"H
Specs	Page 9, Row 13



BEST SELLER

*Manufactured in ND & TX

THV02500

Capacity	2,680 Gallons
Dimensions	90"D x 113"H
Specs	Page 9, Row 16



BEST SELLER

*Manufactured in ND & TX

THV01750

Capacity	2,009 Gallons
Dimensions	85"D x 89"H
Specs	Page 9, Row 20



BEST SELLER

*Manufactured in ND & TX

THV01550

Capacity	1,700 Gallons
Dimensions	85"D x 80"H
Specs	Page 9, Row 22

Featured Image: 3,000 Gallon Flat Bottom Storage Tank (THV03000)



DURABILITY TEST



[YouTube.com/Enduraplas](https://www.youtube.com/Enduraplas)

ENDURAPLAS
VS
4,500 lb SUV



ENGINEERED FOR ENDURANCE®

CONE BOTTOM STORAGE TANKS



Featured Image: 5,000 Gallon Cone Bottom Storage Tanks (THC05000K)

THC SERIES



Featured Image: 10,000 Gallon Cone Bottom Storage Tanks (THC10000K)

ENDURAPLAS ADVANTAGE

STRONG-X™ ROOF DESIGN

The beefed-up roof structure with molded-in truss-like supports eliminates collapsing in extreme weather conditions.

ROTO-MOLD CONSTRUCTION

When cooked and cooled at an even rate, the raw material is bonded together to make this tank virtually indestructible.

SINGLE-PIECE™ CONSTRUCTION

Rotationally-molded in a single mold means the tank is seamless, water-tight and leak-proof.

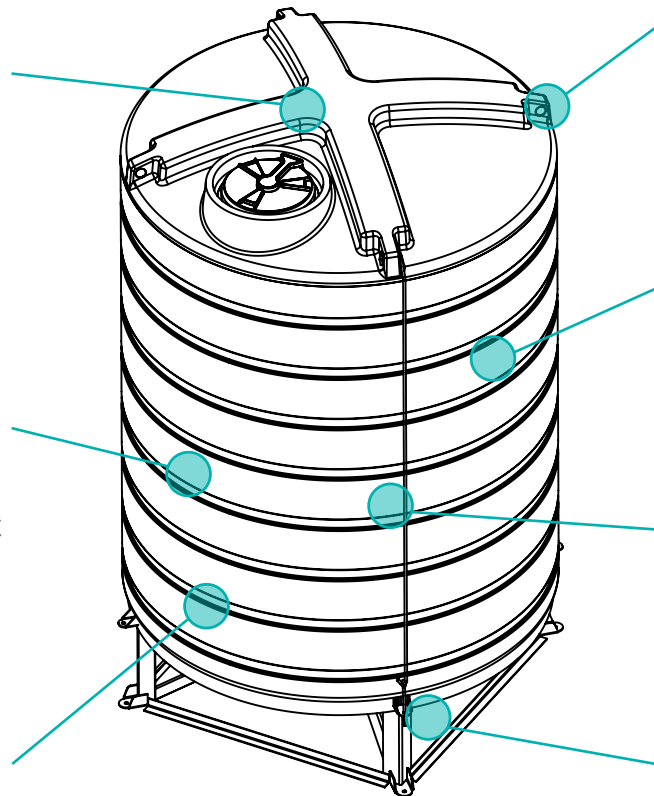

ANCHOR-POINT™ LUGS

Four hefty built-in lifting and tie-down points at each corner make it easy to handle.

RIBBED-WALL™ STRUCTURE

The ribs act like belts around the tank keeping it in shape. This reduces bulging.

THICK-WALL™ DESIGN

Extra-thick walls provide unmatched strength and durability.

AUTO-DRAIN™ CONE BASE

The 15° cone base channels every ounce of liquid to the drain. No more cleaning.

THC SERIES SPECS - LARGE TANKS

	PRODUCT CODE	TANK SIZE (GAL)	DIAMETER	HEIGHT	STAND INCLUDED	LID SIZE	FITTING SIZE	SPECIFIC GRAVITY	TIE DOWN POINTS	CONE SLOPE	WARRANTY	COLORS**	MANUFACTURED IN*	
	THC SERIES													
BEST SELLER	1	THC10000K	10,400	144"	202"	Yes	16"	3"	1.9	Yes	15°	*10 Years	Green, Black	ND, TX
	2	THC10000	10,400	144"	193"	No	16"	3"	1.9	Yes	15°	*10 Years	Green, Black	ND, TX
	3	THC08000K	8,150	144"	166"	Yes	16"	3"	1.9	Yes	15°	*10 Years	Green, Black	ND, TX
	4	THC08000	8,150	144"	158"	No	16"	3"	1.9	Yes	15°	*10 Years	Green, Black	ND, TX
	5	THC07011K	7,011	144"	150"	Yes	16"	3"	1.9	Yes	15°	*10 Years	Green, Black	ND, TX
	6	THC07011	7,011	144"	141"	No	16"	3"	1.9	Yes	15°	*10 Years	Green, Black	ND, TX
	7	THC06011K	6,011	144"	134"	Yes	16"	3"	1.9	Yes	15°	*10 Years	Green, Black,	ND, TX
	8	THC06011	6,011	144"	125"	No	16"	3"	1.9	Yes	15°	*10 Years	Green, Black	ND, TX
	9	THC06000K	6,500	110"	204"	Yes	16"	3"	1.9	Yes	15°	*10 Years	Green, Black	ND
	10	THC06000	6,500	110"	195"	No	16"	3"	1.9	Yes	15°	*10 Years	Green, Black	ND
BEST SELLER	11	THC05000K	5,500	110"	175"	Yes	16"	3"	1.9	Yes	15°	*10 Years	Green, Black	ND
	12	THC05000	5,500	110"	166"	No	16"	3"	1.9	Yes	15°	*10 Years	Green, Black	ND

**Yellow & White are available upon special request
*ND = North Dakota, TX = Texas

*Warranty must be registered to receive 10 years. See page 51 for details.

Featured Image: 10,000 Gallon Cone Bottom Storage Tanks (THC10000K)



"Well built tanks that will last a long time."

Enduraplas THV03000
Brett - USA West

THC SERIES SPECS - SMALL TANKS

	PRODUCT CODE	TANK SIZE (GAL)	DIAMETER	HEIGHT	STAND INCLUDED	LID SIZE	FITTING SIZE	SPECIFIC GRAVITY	TIE DOWN POINTS	CONE SLOPE	WARRANTY	COLORS**	MANUFACTURED IN*	
	THC SERIES													
	13	THC04000K	4,100	110"	146"	Yes	16"	3"	1.9	Yes	15°	*10 Years	Green, Black	ND
	14	THC04000	4,100	110"	135"	No	16"	3"	1.9	Yes	15°	*10 Years	Green, Black	ND
	15	THC03200K	3,300	110"	126"	Yes	16"	3"	1.9	Yes	15°	*10 Years	Green, Black	ND
	16	THC03200	3,300	110"	116"	No	16"	3"	1.9	Yes	15°	*10 Years	Green, Black	ND
BEST SELLER	17	THC03000K	3,126	90"	146"	Yes	16"	3"	1.9	Yes	15°	*10 Years	Green, Black	ND, TX
	18	THC03000	3,126	90"	136"	No	16"	3"	1.9	Yes	15°	*10 Years	Green, Black	ND, TX
	19	THC02520K	2,600	110"	108"	Yes	16"	3"	1.9	Yes	15°	*10 Years	Green, Black	ND
	20	THC02520	2,600	110"	99"	No	16"	3"	1.9	Yes	15°	*10 Years	Green, Black	ND
BEST SELLER	21	THC02500K	2,680	90"	130"	Yes	16"	3"	1.9	Yes	15°	*10 Years	Green, Black	ND, TX
	22	THC02500	2,680	90"	120"	No	16"	3"	1.9	Yes	15°	*10 Years	Green, Black	ND, TX
	23	THC02000K	2,276	90"	123"	Yes	16"	3"	1.9	Yes	15°	*10 Years	Green, Black	ND, TX
	24	THC02000	2,276	90"	113"	No	16"	3"	1.9	Yes	15°	*10 Years	Green, Black	ND, TX
	25	THC01600K	1,700	90"	96"	Yes	16"	3"	1.9	Yes	15°	*10 Years	Green, Black	ND, TX
	26	THC01600	1,700	90"	86"	No	16"	3"	1.9	Yes	15°	*10 Years	Green, Black	ND, TX
BEST SELLER	27	THC01550K	1,700	85"	95"	Yes	16"	3"	1.9	Yes	15°	*10 Years	Green, Black	ND
	28	THC01550	1,700	85"	87"	No	16"	3"	1.9	Yes	15°	*10 Years	Green, Black	ND
	29	THC01350K	1,530	85"	86"	Yes	16"	3"	1.9	Yes	15°	*10 Years	Green, Black	ND
	30	THC01350	1,530	85"	75"	No	16"	3"	1.9	Yes	15°	*10 Years	Green, Black	ND
	31	THC01200K	1,250	90"	83"	Yes	16"	3"	1.9	Yes	15°	*10 Years	Green, Black	ND, TX
	32	THC01200	1,250	90"	73"	No	16"	3"	1.9	Yes	15°	*10 Years	Green, Black	ND, TX
	33	THC01100K	1,100	60"	113"	Yes	16"	3"	1.9	Yes	15°	*10 Years	Green, Black	ND, TX
	34	THC01100	1,100	60"	103"	No	16"	3"	1.9	Yes	15°	*10 Years	Green, Black	ND, TX
	35	THC00870K	870	60"	95"	Yes	16"	3"	1.9	Yes	15°	*10 Years	Green, Black	ND, TX
	36	THC00870	870	60"	85"	No	16"	3"	1.9	Yes	15°	*10 Years	Green, Black	ND, TX
	37	THC00550K	550	60"	69"	Yes	16"	3"	1.9	Yes	15°	*10 Years	Green, Black	ND, TX
	38	THC00550	550	60"	59"	No	16"	3"	1.9	Yes	15°	*10 Years	Green, Black	ND, TX

**Yellow & White are available upon special request
*ND = North Dakota, TX = Texas

*Warranty must be registered to receive 10 years. See page 51 for details.



THC SERIES



BEST SELLER

*Manufactured in ND & TX

THC10000K	
Capacity	10,400 Gallons
Dimensions	144"D x 202"H
Specs	Page 14, Row 1



BEST SELLER

*Manufactured in ND

THC05000K	
Capacity	5,500 Gallons
Dimensions	110"D x 175"H
Specs	Page 14, Row 11



BEST SELLER

*Manufactured in ND & TX

THC03000K	
Capacity	3,126 Gallons
Dimensions	90"D x 146"H
Specs	Page 15, Row 17



BEST SELLER

*Manufactured in ND & TX

THC02500K	
Capacity	2,680 Gallons
Dimensions	90"D x 130"H
Specs	Page 15, Row 21



BEST SELLER

*Manufactured in ND

THC01550K	
Capacity	1,700 Gallons
Dimensions	85"D x 95"H
Specs	Page 15, Row 27

Actual cone stand structure may be different than pictured. Please request drawings if needed.

Featured Image: 5,000 Gallon Cone Bottom Storage Tanks (THC05000K)





"Very good product for the price.
Started out buying two tanks and
have since bought two more."

Enduraplas THV03000
Matt- USA Midwest

Featured Image: 10,000 Gallon Cone Bottom Storage Tanks (THC10000K)

FREESTANDING TRANSPORT TANKS



Featured Image: 3,000 Gallon Freestanding Transport Tanks (THF03000)

THF SERIES



Featured Image: 4,500 Gallon Freestanding Transport Tanks (THF04500)

ENDURAPLAS ADVANTAGE

LIFTING-LUGS™

Built-in and engineered to take the *weight of the tank, these make lifting the tank on and off the trailer a breeze.

*Dry Weight Only

PIN-MOUNT™ SYSTEM

The molded-in mounting lugs combined with heavy-duty steel pins will keep this tank fixed without movement. No hoops. No bands. No maintenance.

THICK-WALL™ DESIGN

Extra-thick walls provide unmatched strength and durability.

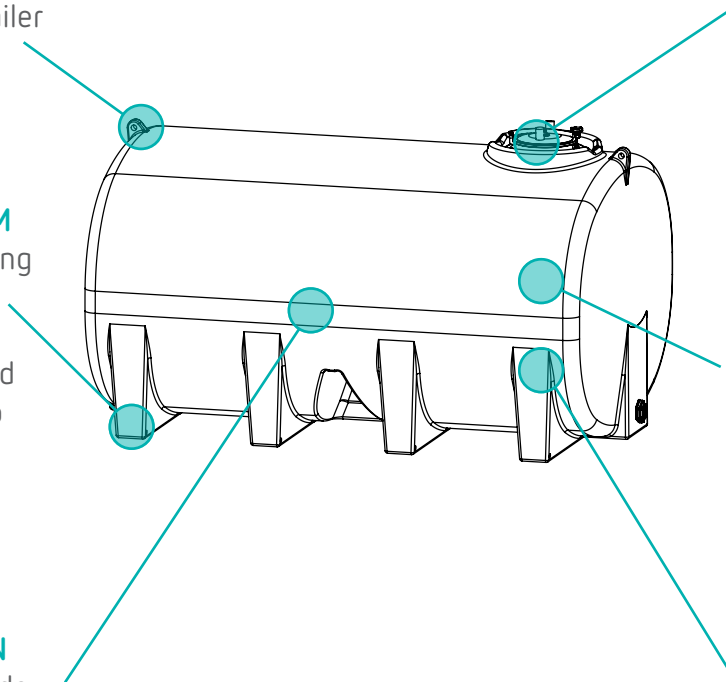

ANTI-SPLASH™ STAINLESS LID

Lockable and spill-proof, this lid keeps liquid in while traveling on rough terrain. (Only on tanks 1,600 gallons and larger).

ROTO-MOLD CONSTRUCTION

When cooked and cooled at an even rate, the raw material is bonded together to make this tank virtually indestructible.

SINGLE-PIECE™ CONSTRUCTION

Rotationally-molded in a single mold means the tank is seamless, water-tight and leak-proof.

THF SERIES SPECS - LARGE TANKS

	PRODUCT CODE	TANK SIZE (GAL)	LENGTH	WIDTH	HEIGHT	MOUNTING PINS INCLUDED	LID SIZE	LID TYPE	FITTING SIZE	SPECIFIC GRAVITY	WARRANTY	COLORS**	MANUFACTURED IN*	
	THF SERIES													
BEST SELLER	1	THF04500	4,500	179"	95"	84"	8 x AZP04	16"	Stainless Steel	3"	1.9	*10 Years	Green, Black	ND
	2	THF03500	3,500	179"	95"	70"	8 x AZP04	16"	Stainless Steel	3"	1.9	*10 Years	Green, Black	ND
BEST SELLER	3	THF03200	3,200	145"	97"	79"	8 x AZP04	16"	Stainless Steel	3"	1.9	*10 Years	Green, Black	ND
	4	THF03000	3,000	130"	87"	90"	8 x AZP04	16"	Stainless Steel	3"	1.9	*10 Years	Green, Black	ND
	5	THF02800	2,800	145"	97"	75"	8 x AZP04	16"	Stainless Steel	3"	1.9	*10 Years	Green, Black	ND
BEST SELLER	6	THF02500	2,500	130"	87"	75"	8 x AZP04	16"	Stainless Steel	3"	1.9	*10 Years	Green, Black	ND

**Yellow & White are available upon special request
*ND = North Dakota, TX = Texas

*Warranty must be registered to receive 10 years. See page 51 for details.

Featured Image: 2,500 Gallon Freestanding Transport Tanks (THF02500)



"My tank is the 3rd one I have purchased. They are all very rugged and function with the ease and reliability I expect. I would recommend this to anyone wanting a tough tank that will last for years."

Enduraplas THD01200
Ron - USA Midwest

THF SERIES SPECS - SMALL TANKS

	PRODUCT CODE	TANK SIZE (GAL)	LENGTH	WIDTH	HEIGHT	MOUNTING PINS INCLUDED	LID SIZE	LID TYPE	FITTING SIZE	SPECIFIC GRAVITY	WARRANTY	COLORS**	MANUFACTURED IN*	
	THF SERIES													
7	THF02200	2,200	130"	71"	72"	8 x AZP04	16"	Stainless Steel	3"	1.9	*10 Years	Green, Black	ND	
8	THF01900	1,900	130"	71"	65"	8 x AZP04	16"	Stainless Steel	3"	1.9	*10 Years	Green, Black	ND	
BEST SELLER	9	THF01600	1,600	130"	71"	59"	8 x AZP04	16"	Stainless Steel	3"	1.9	*10 Years	Green, Black	ND
	10	THF01400	1,400	102"	70"	66"	6 x AZP04	16"	Poly	2"	1.9	*10 Years	Green, Black	ND
	11	THF01200	1,200	102"	70"	59"	6 x AZP04	16"	Poly	2"	1.9	*10 Years	Green, Black	ND
	12	THF01000	1,100	94"	60"	63"	6 x AZP03	16"	Poly	2"	1.9	*10 Years	Green, Black	ND
	13	THF00800	800	94"	60"	48"	6 x AZP03	16"	Poly	2"	1.9	*10 Years	Green, Black	ND
	14	THF00500	550	80"	57"	40"	6 x AZP03	16"	Poly	2"	1.9	*10 Years	Green, Black	ND
	15	THF00400	400	74"	46"	37"	4 x AZP02	16"	Poly	2"	1.9	*10 Years	Green, Black	ND
	16	THF00300	340	74"	46"	31"	4 x AZP02	16"	Poly	2"	1.9	*10 Years	Green, Black	ND
	17	THF00250	260	55"	47"	34"	4 x AZP01	16"	Poly	2"	1.9	*10 Years	Green, Black	ND
	18	THF00200	200	55"	47"	27"	4 x AZP01	16"	Poly	2"	1.9	*10 Years	Green, Black	ND
	19	THF00150	160	46"	41"	28"	4 x AZP01	8"	Poly	2"	1.9	*10 Years	Green, Black	ND
	20	THF00100	110	46"	41"	21"	4 x AZP01	8"	Poly	2"	1.9	*10 Years	Green, Black	ND

**Yellow & White are available upon special request
*ND = North Dakota, TX = Texas

*Warranty must be registered to receive 10 years. See page 51 for details.

Featured Image: 4,500 Gallon Freestanding Transport Tanks (THF04500)





THF SERIES

BEST SELLER



*Mounting Pins Included = 8 x AZP04

THF04500

Capacity	4,500 Gallons
Dimensions	179"L x 95"W x 84"H
Specs	Page 20, Row 1

*Manufactured in ND

BEST SELLER



*Mounting Pins Included = 8 x AZP04

THF03200

Capacity	3,200 Gallons
Dimensions	145"L x 97"W x 79"H
Specs	Page 20, Row 3

*Manufactured in ND

BEST SELLER



*Mounting Pins Included = 8 x AZP04

THF02500

Capacity	2,500 Gallons
Dimensions	130"L x 87"W x 75"H
Specs	Page 20, Row 6

*Manufactured in ND

BEST SELLER



*Mounting Pins Included = 8 x AZP04

THF01600

Capacity	1,600 Gallons
Dimensions	130"L x 71"W x 59"H
Specs	Page 21, Row 9

*Manufactured in ND

Featured Image: 3,000 Gallon Freestanding Transport Tanks (THF03000)



DURABILITY TEST



[YouTube.com/Enduraplas](https://www.youtube.com/Enduraplas)

ENDURAPLAS
VS
30 TON CRANE

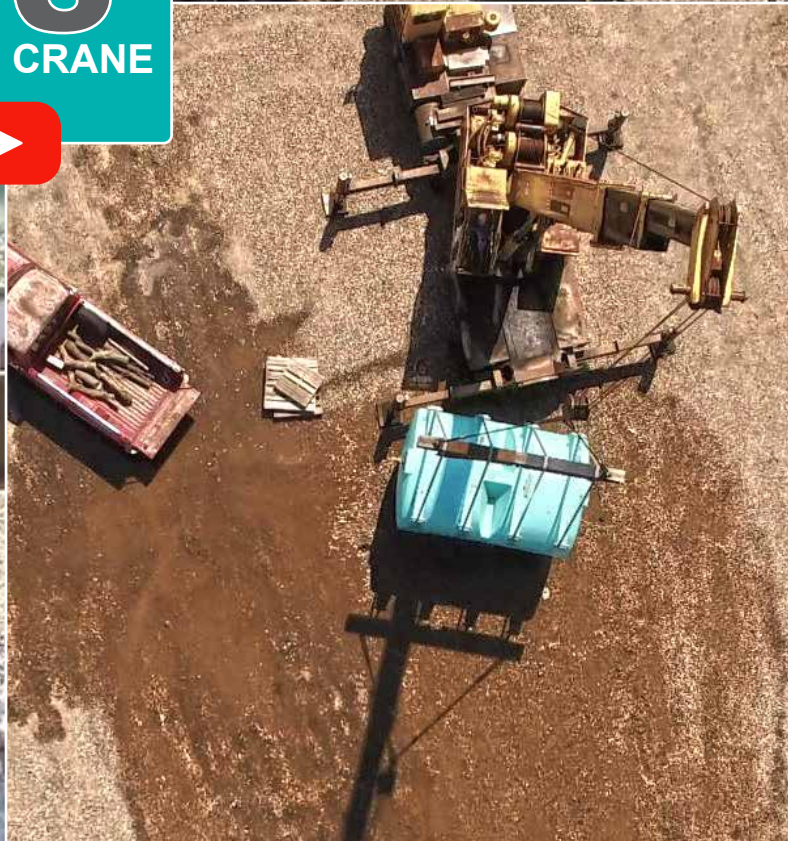

ENGINEERED FOR ENDURANCE®

SUMP BOTTOM TRANSPORT TANKS



Featured Image: (100% drain-out) 3,200 Gallon Sump Bottom Transport Tank (THD03200K)

THD SERIES



Featured Image: (100% drain-out) 3,200 Gallon Sump Bottom Transport Tank (THD03200K)



LIFTING-LUGS™

Built-in and engineered to take the *weight of the tank, these make lifting the tank on and off the trailer a breeze.

*Dry Weight Only

THICK-WALL™ DESIGN

Extra-thick walls provide unmatched strength and durability.

PIN-MOUNT™ SYSTEM

The molded-in mounting lugs combined with heavy-duty steel pins will keep this tank fixed without movement. No hoops. No bands. No maintenance.

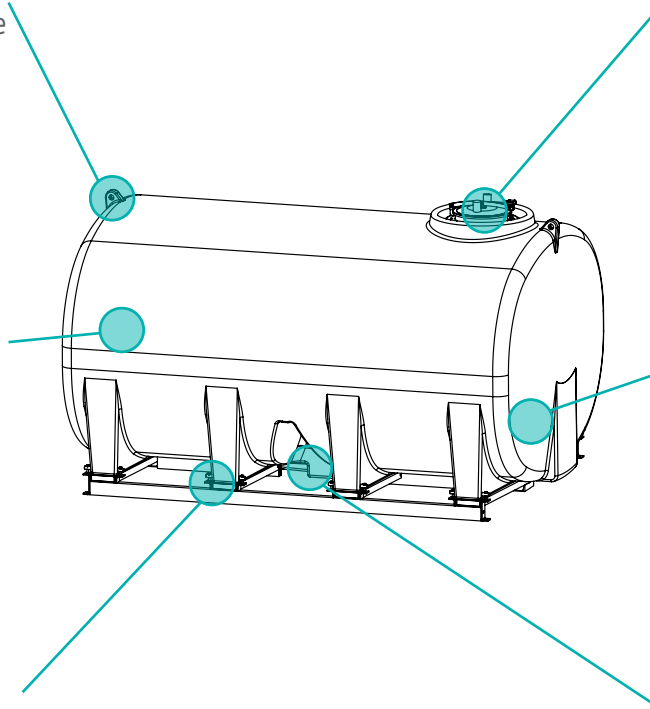

ANTI-SPLASH™ STAINLESS LID

Lockable and spill-proof, this lid keeps liquid in while traveling on rough terrain. (Only on tanks 1,600 gallons and larger).

SINGLE-PIECE™ CONSTRUCTION

Rotationally-molded in a single mold means the tank is seamless, water-tight and leak-proof.

AUTO-DRAIN™ SUMP BASE

The sloped tank base channels every ounce of liquid to the drain. Just where it should go.

THD SERIES SPECS - LARGE TANKS

	PRODUCT CODE	TANK SIZE (GAL)	LENGTH	WIDTH	HEIGHT	MOUNTING PINS REQUIRED	FRAME INCLUDED	LID SIZE	LID TYPE	SPECIFIC GRAVITY	WARRANTY	COLORS**	MANUFACTURED IN*	
THD SERIES														
BEST SELLER	1	THD03200K	3,200	145"	97"	84"	8 x AZP04 Included	Yes	16"	Stainless Steel	1.9	*10 Years	Green, Black	ND
	2	THD03200	3,200	145"	97"	83"	8 x AZP04	No	16"	Stainless Steel	1.9	*10 Years	Green, Black	ND
	3	THD03000K	3,000	130"	87"	94"	8 x AZP04 Included	Yes	16"	Stainless Steel	1.9	*10 Years	Green, Black	ND
	4	THD03000	3,000	130"	87"	93"	8 x AZP04	No	16"	Stainless Steel	1.9	*10 Years	Green, Black	ND
	5	THD02800K	2,800	145"	97"	76"	8 x AZP04 Included	Yes	16"	Stainless Steel	1.9	*10 Years	Green, Black	ND
	6	THD02800	2,800	145"	97"	75"	8 x AZP04	No	16"	Stainless Steel	1.9	*10 Years	Green, Black	ND
BEST SELLER	7	THD02500K	2,500	130"	87"	78"	8 x AZP04 Included	Yes	16"	Stainless Steel	1.9	*10 Years	Green, Black	ND
	8	THD02500	2,500	130"	87"	77"	8 x AZP04	No	16"	Stainless Steel	1.9	*10 Years	Green, Black	ND

**Yellow & White are available upon special request
*ND = North Dakota, TX = Texas

*Warranty must be registered to receive 10 years. See page 51 for details.

TANK WEDGES



- Can only be used with THD3200 and THD2800
- Reduces the height of the tank and means you won't need a frame.

AZSW0001

THD2800	8 Needed
THD3200	8 Needed

Featured Image: 3,000 Gallon Sump Bottom Transport Tanks (THD03000K)



THD SERIES SPECS - SMALL TANKS

	PRODUCT CODE	TANK SIZE (GAL)	LENGTH	WIDTH	HEIGHT	MOUNTING PINS REQUIRED	FRAME INCLUDED	LID SIZE	LID TYPE	SPECIFIC GRAVITY	WARRANTY	COLORS**	MANUFACTURED IN*	
	THD SERIES													
9	THD02200K	2,200	130"	71"	76"	8 x AZP04 Included	Yes	16"	Stainless Steel	1.9	*10 Years	Green, Black	ND	
10	THD02200	2,200	130"	71"	75"	8 x AZP04	No	16"	Stainless Steel	1.9	*10 Years	Green, Black	ND	
11	THD01900K	1,900	130"	71"	70"	8 x AZP04 Included	Yes	16"	Stainless Steel	1.9	*10 Years	Green, Black	ND	
12	THD01900	1,900	130"	71"	79"	8 x AZP04	No	16"	Stainless Steel	1.9	*10 Years	Green, Black	ND	
BEST SELLER	13	THD01600K	1,600	130"	71"	60"	8 x AZP04 Included	Yes	16"	Stainless Steel	1.9	*10 Years	Green, Black	ND
	14	THD01600	1,600	130"	71"	59"	8 x AZP04	No	16"	Stainless Steel	1.9	*10 Years	Green, Black	ND
	15	THD01400K	1,400	102"	70"	71"	6 x AZP04 Included	Yes	16"	Poly	1.9	*10 Years	Green, Black	ND
	16	THD01400	1,400	102"	70"	70"	6 x AZP04	No	16"	Poly	1.9	*10 Years	Green, Black	ND
	17	THD01200K	1,200	102"	70"	64"	6 x AZP04 Included	Yes	16"	Poly	1.9	*10 Years	Green, Black	ND
	18	THD01200	1,200	102"	70"	63"	6 x AZP04	No	16"	Poly	1.9	*10 Years	Green, Black	ND
	19	THD01010K	1,010	130"	49"	59"	8 x AZP03 Included	Yes	16"	Poly	1.9	*10 Years	Green, Black	TX
	20	THD01010	1,010	130"	49"	58.5"	8 x AZP03	No	16"	Poly	1.9	*10 Years	Green, Black	TX
	21	THD01000K	1,100	94"	60"	71"	6 x AZP03 Included	Yes	16"	Poly	1.9	*10 Years	Green, Black	ND
	22	THD01000	1,100	94"	60"	70"	6 x AZP03	No	16"	Poly	1.9	*10 Years	Green, Black	ND
	23	THD00800K	800	94"	60"	56"	6 x AZP03 Included	Yes	16"	Poly	1.9	*10 Years	Green, Black	ND
	24	THD00800	800	94"	60"	55"	6 x AZP03	No	16"	Poly	1.9	*10 Years	Green, Black	ND
	25	THD00500K	550	80"	57"	49"	6 x AZP03 Included	Yes	16"	Poly	1.9	*10 Years	Green, Black	ND
	26	THD00500	550	80"	57"	48"	6 x AZP03	No	16"	Poly	1.9	*10 Years	Green, Black	ND
	27	THD00400K	400	74"	46"	45"	4 x AZP02 Included	Yes	16"	Poly	1.9	*10 Years	Green, Black	ND
	28	THD00400	400	74"	46"	42"	4 x AZP02	No	16"	Poly	1.9	*10 Years	Green, Black	ND
	29	THD00300K	340	74"	46"	36"	4 x AZP02 Included	Yes	16"	Poly	1.9	*10 Years	Green, Black	ND
	30	THD00300	340	74"	46"	34"	4 x AZP02	No	16"	Poly	1.9	*10 Years	Green, Black	ND
	31	THD00250K	260	55"	47"	38"	4 x AZP01 Included	Yes	16"	Poly	1.9	*10 Years	Green, Black	ND
	32	THD00250	260	55"	47"	37"	4 x AZP01	No	16"	Poly	1.9	*10 Years	Green, Black	ND
	33	THD00200K	210	55"	47"	32"	4 x AZP01 Included	Yes	16"	Poly	1.9	*10 Years	Green, Black	ND
	34	THD00200	210	55"	47"	31"	4 x AZP01	No	16"	Poly	1.9	*10 Years	Green, Black	ND
	35	THD00150K	160	46"	41"	34"	4 x AZP01 Included	Yes	8"	Poly	1.9	*10 Years	Green, Black	ND
	36	THD00150	160	46"	41"	33"	4 x AZP01	No	8"	Poly	1.9	*10 Years	Green, Black	ND
	37	THD00100K	110	46"	41"	28"	4 x AZP01 Included	Yes	8"	Poly	1.9	*10 Years	Green, Black	ND
	38	THD00100	110	46"	41"	27"	4 x AZP01	No	8"	Poly	1.9	*10 Years	Green, Black	ND

**Yellow & White are available upon special request
*ND = North Dakota, TX = Texas

*Warranty must be registered to receive 10 years. See page 51 for details.



THD SERIES

BEST SELLER



*Mounting Pins Included = 8 x AZP04

THD03200K

Capacity	3,200 Gallons
Dimensions	145"L x 97"W x 84"H
Specs	Page 26, Row 1

*Manufactured in ND

BEST SELLER



*Mounting Pins Included = 8 x AZP04

THD02500K

Capacity	2,500 Gallons
Dimensions	130"L x 87"W x 78"H
Specs	Page 26, Row 7

*Manufactured in ND

BEST SELLER



*Mounting Pins Included = 8 x AZP04

THD01600K

Capacity	1,600 Gallons
Dimensions	130"L x 71"W x 60"H
Specs	Page 27, Row 13

*Manufactured in ND



*Manufactured in TX

*Mounting Pins Included = 8 x AZP03

THD01010K

Capacity	1,010 Gallons
Dimensions	130"L x 49"W x 59"H
Specs	Page 27, Row 19

Featured Image: 3,000 Gallon Sump Bottom Transport Tank (THD03000K)



PICKUP KING™



	PRODUCT CODE	TANK SIZE (GAL)	DIMENSIONS (HEIGHT)	DIMENSIONS (TOP WIDTH)	DIMENSIONS (BOTTOM WIDTH)	FITTING SIZE	LID SIZE	SPECIFIC GRAVITY	WARRANTY	COLORS
	PICKUP KING™									
1	TLV00275	275	29"	60"	48"	2"	16"	1.1	*10 Years	White
2	TLV00400	400	40"	60"	48"	2"	16"	1.1	*10 Years	White

*Warranty must be registered to receive 10 years. See page 51 for details.



Perfect shape for your pickup

Integrated wheel well design to reduce tank movement.



Superior structure for extra durability

The STRONG-X™ roof design and RIBBED-WALL™ design eliminates cracks in transit.



Built-in tie down points

Each tank comes standard with 4 tie down points to safely secure your load.



Extra tough ribbed wall design

The ribs act like belts around the tank keeping it in shape. This reduces bulging.



TLV00275	
Capacity	275 Gallons
Dimensions	29"H
Specs	Page 29, Row 1



TLV00400	
Capacity	400 Gallons
Dimensions	40"H
Specs	Page 29, Row 2



ALL ENGINEERED FROM



Available from
one manufacturer.

AG SERIES NURSE TRAILERS



The AG Series nurse trailers are a perfect economic, cost effective option for transporting liquid around your farm or ranch. These were designed to meet the high demand of a basic trailer that needs to be tough, durable and above all, reliable. These trailers are built with premium brand components at an affordable price.

DOT SERIES NURSE TRAILERS



These DOT approved and HWY ready nurse trailers come with every feature you'll need to get the job done quicker. On this trailer, we only use the highest quality tanks, pumps and plumbing accessories. While these were designed to meet the expectations of the customer, we still included some extra features that exceed the basic requests we received.

Sold & serviced by
your local dealer.



DOUBLE & TRIPLE CONE BOTTOM TRAILERS



The cone bottom trailer range has simply been engineered from feedback we have received from real farmers that rely on this product every season. Every cone trailer comes with features like the unique jacking system and 100% drain plumbing design. These trailers are a perfect portable bulk storage solution that allows you to move your liquid where you need it.

TENDER TANK TRAILERS



These tender tank trailers are another masterpiece of our customers requests. Unlike other semi trailers on the market, the entire tank plumbing is now under the deck. This gives you more useful space on your trailer deck that you won't get anywhere else. These trailers are designed to perform better with premium products.

NURSE TRAILERS



Featured Image: 1,200 Gallon DOT Series Nurse Trailer (WNI12FGOL4800)

NURSE TRAILER SPECS

	AG SERIES - PAGE 35				DOT SERIES - PAGE 37					
	1	2	3	4	5	6	7	8	9	10
TANK SIZE (GAL)	500	1,100	1,200	1,600	500	800	1,010	1,100	1,200	1,600
DIMENSIONS (L X W X H)	134" x 77" x 74"	158" x 84" x 88"	175" x 96" x 85"	203" x 106" x 96"	134" x 78" x 74"	158" x 80" x 73"	195" x 73" x 78"	158" x 80" x 88"	175" x 92" x 85"	203" x 102" x 84"
DOT COMPLIANT	No	No	No	No	Yes	Yes	Yes	Yes	Yes	Yes
FRAME CONSTRUCTION	5" x 2" Rectangle Tubing	6" x 2" Rectangle Tubing	6" x 2" Rectangle Tubing	8" x 2" Rectangle Tubing	5" x 2" Rectangle Tubing	6" x 2" Rectangle Tubing	6" x 2" Rectangle Tubing	6" x 2" Rectangle Tubing	6" x 2" Rectangle Tubing	8" x 2" Rectangle Tubing
AXLE (S)	1 x 7,000 lbs. Slipper Spring	2 x 7,000 lbs. Slipper Spring	2 x 7,000 lbs. Slipper Spring	2 x 10,000 lbs. Slipper Spring	1 x 7,000 lbs. Slipper Spring	2 x 7,000 lbs. Slipper Spring	2 x 7,000 lbs. Slipper Spring	2 x 7,000 lbs. Slipper Spring	2 x 7,000 lbs. Slipper Spring	2 x 10,000 lbs. Slipper Spring
TIRES	235/80 R16 10 PLY HWY Tire on Ag Wheel	235/80 R16 10 PLY HWY Tire on Ag Wheel	235/80 R16 10 PLY HWY Tire on Ag Wheel	385/65 R22.5 18 PLY Super Single on Ag Wheel	235/80 R16 10 PLY DOT Tire & Wheel	235/80 R16 10 PLY DOT Tire & Wheel	235/80 R16 10 PLY DOT Tire & Wheel	235/80 R16 10 PLY DOT Tire & Wheel	235/80 R16 10 PLY DOT Tire & Wheel	235/75 R17.5 18 PLY DOT Tire & Wheel
BRAKES	No	No	No	Electric with emergency breakaway (1 x Axle)	Electric with emergency breakaway (2 x Axle)	Electric with emergency breakaway (2 x Axle)	Electric with emergency breakaway (2 x Axle)	Electric with emergency breakaway (2 x Axle)	Electric with emergency breakaway (2 x Axle)	Electric with emergency breakaway (2 x Axle)
FENDERS	No	No	No	No	Yes	Yes	Yes	Yes	Yes	Yes
LIGHTS	No	No	No	No	DOT compliant clearance/ stop/turn/ tail/license	DOT compliant clearance/ stop/turn/ tail/license	DOT compliant clearance/ stop/turn/ tail/license	DOT compliant clearance/ stop/turn/ tail/license	DOT compliant clearance/ stop/turn/ tail/license	DOT compliant clearance/ stop/turn/ tail/license
ELECTRICAL PLUG	No	No	No	7 Pole RV Plug	7 Pole RV Plug	7 Pole RV Plug	7 Pole RV Plug	7 Pole RV Plug	7 Pole RV Plug	7 Pole RV Plug
HITCH TYPE	20,000 lbs. Clevis	20,000 lbs. Clevis	20,000 lbs. Clevis	20,000 lbs. Clevis	20,000 lbs. 2 - 5/16" Ball	20,000 lbs. 2 - 5/16" Ball	20,000 lbs. 2 - 5/16" Ball	20,000 lbs. 2 - 5/16" Ball	20,000 lbs. 2 - 5/16" Ball	21,000 lbs. 2 - 5/16" Ball
TANK TYPE	Poly sump bottom transport tank	Poly sump bottom transport tank	Poly sump bottom transport tank	Poly sump bottom transport tank	Poly sump bottom transport tank	Poly sump bottom transport tank	Poly sump bottom transport tank	Poly sump bottom transport tank	Poly sump bottom transport tank	Poly sump bottom transport tank
TANK COLOR	Green	Green	Green	Green	Green	Green	Green	Green	Green	Green
MOTOR	Briggs & Stratton® 6.5 HP	Briggs & Stratton® 6.5 HP	Briggs & Stratton® 6.5 HP	Briggs & Stratton® 6.5 HP	Honda® GX160 5.5 HP	Honda® GX160 5.5 HP	Honda® GX160 5.5 HP	Honda® GX160 5.5 HP	Honda® GX160 5.5 HP	Honda® GX160 5.5 HP
PUMP	2" Banjo® Centrifugal Poly, 195 GPM	2" Banjo® Centrifugal Poly, 195 GPM	2" Banjo® Centrifugal Poly, 195 GPM	2" Banjo® Centrifugal Poly, 195 GPM	2" Banjo® Centrifugal Poly, 195 GPM	2" Banjo® Centrifugal Poly, 195 GPM	2" Banjo® Centrifugal Poly, 195 GPM	2" Banjo® Centrifugal Poly, 195 GPM	2" Banjo® Centrifugal Poly, 195 GPM	2" Banjo® Centrifugal Poly, 195 GPM
VALVE FITTINGS	2" Banjo® sweep manifold	2" Banjo® sweep manifold	2" Banjo® sweep manifold	2" Banjo® sweep manifold	2" Banjo® sweep manifold	2" Banjo® sweep manifold	2" Banjo® sweep manifold	2" Banjo® sweep manifold	2" Banjo® sweep manifold	2" Banjo® sweep manifold
HOSE SIZE / TYPE	2" /Black Fertilizer	2" /Black Fertilizer	2" /Black Fertilizer	2" /Black Fertilizer	2" /Black Fertilizer	2" /Black Fertilizer	2" /Black Fertilizer	2" /Black Fertilizer	2" /Black Fertilizer	2" /Black Fertilizer
DISCHARGE HOSE LENGTH	15'	20'	20'	20'	15'	20'	20'	20'	20'	20'
DRY WEIGHT (LBS)	900	1,610	1,940	3,800	950	1,560	1,620	1,650	2,035	3,350

*Manufactured in TX



AG SERIES



A perfect economic, cost effective option for transporting liquid around your farm or ranch. The Ag Series nurse trailer family has been designed to withstand rough treatment when work is getting done.

Featured Image (Above): 1,200 Gallon Ag Series Nurse Trailer (WNC12FGOR9801)



Standard with a Briggs & Stratton® Engine

Enjoy an affordable high quality pump and engine on every trailer.



Keep your discharge hose safe

All hoses are stored in a designated spot to avoid the possibility of them tangling.



Superior design tube frame

All Ag Series nurse trailers come equipped with an extra strong constructed frame.

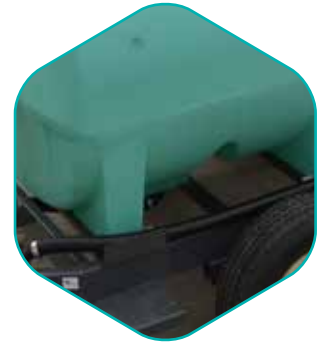

Completely drain your tank

By utilizing the superior sump tank, you can drain your tank to the last drop.



Site Gauge Kit



Recirculation Kit



2" Honda® & Side Fill Kit



4' Wood Deck Kit



30 Gallon Mixing Cone Kit



3" Honda® Kit

AVAILABLE ON 1,200 - 1,600 GALLON TRAILERS

AG SERIES



500 GALLONS

Capacity	500 Gallons
Dimensions	134"L x 77"W x 74"H
Specs	Page 33, Column 1



1,100 GALLONS

Capacity	1,100 Gallons
Dimensions	158"L x 84"W x 88"H
Specs	Page 33, Column 2



BEST SELLER

1,200 GALLONS

Capacity	1,200 Gallons
Dimensions	175"L x 96"W x 85"H
Specs	Page 33, Column 3



BEST SELLER

1,600 GALLONS

Capacity	1,600 Gallons
Dimensions	203"L x 106"W x 96"H
Specs	Page 33, Column 4

*All 1,600 Gallon Ag Series Nurse Trailers are supplied with quality used tires.

Featured Image: 1,200 Gallon Ag Series Nurse Trailer





DOT SERIES



The DOT series Nurse Trailer family allows you to transport liquid safely while legally driving on state roads. Each trailer is equipped with a Honda® engine and a DOT light kit.

Featured Image (Above): 1,200 Gallon DOT Series Nurse Trailer (WN112FGOL4800)



Sturdy Pin Mount™ Securing System

The Enduraplas exclusive Pin Mount™ System is proven and hassle free.



Honda® engine and Banjo® pump

A high quality engine gives you the confidence to use your trailer all year round.



A complete DOT approved package

All DOT Series trailers come with lights, brakes & fenders that comply with DOT standards



Fitted: discharge hose, side fill & recirculation kit

Easily fill your equipment with high quality hose and fittings.

OPTIONAL ACCESSORIES



Site Gauge Kit



4' Wood Deck Kit



30 Gallon Mixing Cone Kit



AVAILABLE ON 1,200 - 1,600 GALLON TRAILERS

3" Honda® Kit

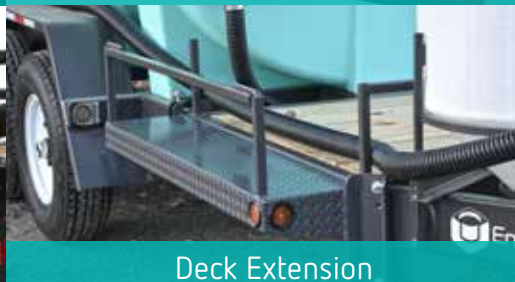

Deck Extension

92" Total Width (1200-1600 gallon trailers)
82" Total Width (1000 gallon trailers)



Fender Basket

DOT SERIES



500 GALLONS

Capacity	550 Gallons
Dimensions	134"L x 78"W x 74"H
Specs	Page 33, Column 5



800 GALLONS

Capacity	800 Gallons
Dimensions	158"L x 80"W x 73"H
Specs	Page 33, Column 6



1,100 GALLONS

Capacity	1,100 Gallons
Dimensions	158"L x 80"W x 88"H
Specs	Page 33, Column 8



BEST SELLER

1,200 GALLONS

Capacity	1,200 Gallons
Dimensions	175"L x 92"W x 85"H
Specs	Page 33, Column 9



BEST SELLER

1,600 GALLONS

Capacity	1,600 Gallons
Dimensions	203"L x 102"W x 84"H
Specs	Page 33, Column 10

73"

***Manufactured in TX**

*Length dimensions are without deck

1,010 GALLONS

Capacity	1,010 Gallons
Dimensions	*195"L x 73"W x 78"H
Specs	Page 33, Column 7

1,200 GALLONS

Capacity	1,200 Gallons
Dimensions	175"L x 92"W x 85"H

CONE BOTTOM TRAILERS



Featured Image: Double Cone 6,000 Gallon Trailer (WCDC60FGOL3801)

CONE BOTTOM TRAILER SPECS

**BEST
SELLER**

	5,000 GALLON DOUBLE CONE - PAGE 41		6,000 GALLON DOUBLE CONE - PAGE 41		9,000 GALLON TRIPLE CONE - PAGE 41	
	1	2	3	4	5	6
TANK SIZE (GAL)	2 x 2,500	2 x 2,500	2 x 3,000	2 x 3,000	3 x 3,000	3 x 3,000
DIMENSIONS (L X W X H)	21' x 100" x (Raised - 158" / Lowered - 146")	21' x 100" x (Raised - 158" / Lowered - 146")	21' x 100" x (Raised - 158" / Lowered - 146")	21' x 100" x (Raised - 158" / Lowered - 146")	29' x 100" x (Raised - 158" / Lowered - 146")	29' x 100" x (Raised - 158" / Lowered - 146")
FRAME CONSTRUCTION	6" x 2" Rectangle Tubing	6" x 2" Rectangle Tubing	6" x 2" Rectangle Tubing	6" x 2" Rectangle Tubing	6" x 2" Rectangle Tubing	6" x 2" Rectangle Tubing
AXLE (S)	2 x 3,500 lbs. Spindle	2 x 3,500 lbs. Spindle	2 x 3,500 lbs. Spindle	2 x 3,500 lbs. Spindle	2 x 3,500 lbs. Spindle	2 x 3,500 lbs. Spindle
TIRES	235 / 80 R16 10 PLY, HWY Tire on Ag Wheel	235 / 80 R16 10 PLY, HWY Tire on Ag Wheel	235 / 80 R16 10 PLY, HWY Tire on Ag Wheel	235 / 80 R16 10 PLY, HWY Tire on Ag Wheel	235 / 80 R16 10 PLY, HWY Tire on Ag Wheel	235 / 80 R16 10 PLY, HWY Tire on Ag Wheel
LIGHTS	(Optional) DOT compliant clearance / stop / turn / tail	(Optional) DOT compliant clearance / stop / turn / tail	(Optional) DOT compliant clearance / stop / turn / tail	(Optional) DOT compliant clearance / stop / turn / tail	(Optional) DOT compliant clearance / stop / turn / tail	(Optional) DOT compliant clearance / stop / turn / tail
ELECTRICAL PLUG WITH LIGHT OPTION	7 Pole RV Plug	7 Pole RV Plug	7 Pole RV Plug	7 Pole RV Plug	7 Pole RV Plug	7 Pole RV Plug
HITCH TYPE	20,000 lbs. Clevis	20,000 lbs. Clevis	20,000 lbs. Clevis	20,000 lbs. Clevis	20,000 lbs. Clevis	20,000 lbs. Clevis
TANK TYPE	Poly cone bottom storage tank	Poly cone bottom storage tank	Poly cone bottom storage tank	Poly cone bottom storage tank	Poly cone bottom storage tank	Poly cone bottom storage tank
TANK COLOR	Green	Green	Green	Green	Green	Green
MOTOR	Honda® GX160 5.5 HP	Honda® GX200 6.5 HP	Honda® GX160 5.5 HP	Honda® GX200 6.5 HP	Honda® GX160 5.5 HP	Honda® GX200 6.5 HP
PUMP	2" Banjo® Centrifugal Poly, 195 GPM	3" Banjo® Centrifugal Poly, 293 GPM	2" Banjo® Centrifugal Poly, 195 GPM	3" Banjo® Centrifugal Poly, 293 GPM	2" Banjo® Centrifugal Poly, 195 GPM	3" Banjo® Centrifugal Poly, 293 GPM
VALVE FITTINGS	3" Feed 2" Discharge Banjo® sweep manifold	3" Feed 3" Discharge Banjo® sweep manifold	3" Feed 2" Discharge Banjo® sweep manifold	3" Feed 3" Discharge Banjo® sweep manifold	3" Feed 2" Discharge Banjo® sweep manifold	3" Feed 3" Discharge Banjo® sweep manifold
HOSE SIZE / TYPE	3" - 2" / Black Fertilizer	3" - 3" / Black Fertilizer	3" - 2" / Black Fertilizer	3" - 3" / Black Fertilizer	3" - 2" / Black Fertilizer	3" - 3" / Black Fertilizer
DRY WEIGHT (LBS)	2,600	2,620	2,800	2,820	4,070	4,090



CONE BOTTOM TRAILER



A perfect portable storage solution for someone that requires liquid in different spots at different times. With new design features, these cone trailers offer a range of user-friendly benefits.

Featured Image (Above): Double and Triple Cone Trailers



Industry leading Ribbed Wall™ tank warranty

You can depend on each Ribbed Wall™ tank to work as hard as you do.



Unique jacking system

Ergonomic jack height with center pull hydraulic ram.



Heavy duty powder coated frame

Extra strong tube frame with built-in hose storage brackets.



A Complete drainage system

Pump position allows you to fully drain all hoses

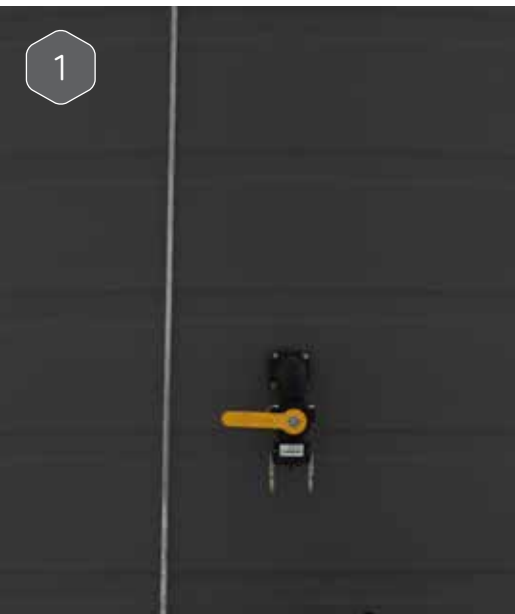

OPTIONAL ACCESSORIES

1

Recirculation Kit

2

Sight Gauge Kit

3

DOT Lights Kit

CONE BOTTOM TRAILER



5000 DOUBLE CONE

Capacity	5,000 Gallons
Specs	Page 39, Column 1 & 2



BEST SELLER

6000 DOUBLE CONE

Capacity	6,000 Gallons
Specs	Page 39, Column 3 & 4



9000 TRIPLE CONE

Capacity	9,000 Gallons
Specs	Page 39, Column 5 & 6



TENDER TANK TRAILERS

42' TENDER TANK TRAILER - PAGE 43	
TANK SIZE RANGE (GAL)	1,600 - 3,200
DIMENSIONS (L X W X H)	*42' x 102" x *(Top Deck - 65"/Bottom Deck - 41")
FRAME CONSTRUCTION	16" I-Beam
AXLE (S)	2 x 25,000 lbs. (ABS on 1 Axle)
TIRES	255/70 R22.5 - 16 PLY DOT Tire & Wheel
LIGHTS	DOT compliant clearance/stop/turn/tail/ABS
CAPACITY	60,000 GVWR
HITCH TYPE	5th Wheel Semi

42' TENDER TANK TRAILER - PAGE 43	
DECKING	Treated Wood, 2" x 8"
TANK TYPE	Poly Sump/Freestanding Transport Tank
TANK COLOR	Black
STANDARD MOTOR	Honda® GX160 6.5 HP
STANDARD PUMP	3" Banjo® Centrifugal Poly, 293 GPM
VALVE FITTINGS	3" Feed 3" Discharge Banjo® sweep manifold
HOSE SIZE/TYPE	3"/Black Fertilizer
WEIGHT (LBS) - TRAILER ONLY	11,900

*42' Tender Tank Trailer Lengths (Top Deck = 12' | Bottom Deck = 30')



Featured Image: 42' Tender Tank Trailer

TENDER TANK TRAILER



TENDER TANK TRAILER

Length	42'
Specs	Page 41, Column 1

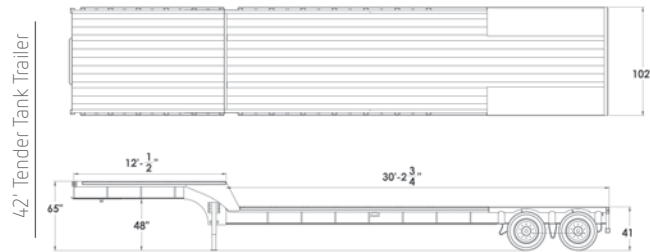

Site Gauge Kit



All Plumbing Under the Deck



Tank Ladder



Flow Center



1,600 - 3,200 Gallon Tanks

Pull or Electric Start Engines / 2" or 3" Pump

ACCESSORIES & PARTS



Featured Image: 45 Gallon Mixing Cone, 2" & 3" plumbing accessories and a Honda® Engine

INTERNAL TANK BAFFLE



Only 1% liquid displacement

The amount of water the baffle displaces is minimal.

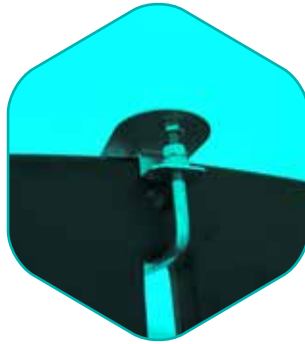

Sturdy mounting process

The baffle is mounted via the roof to keep it extra secure.



Robust engineering and design

The middle planks connect to the vertical end support for added strength.



Stops your truck 16.6% faster

The truck stopped 16.6% faster with the baffle, than without it.

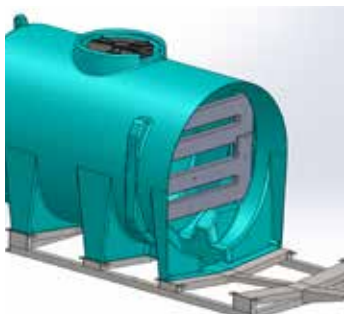

AVB1010

Tank Size	1,010 Gallons
Tank Style	Horizontal



AVB2800

Tank Size	2,800 Gallons
Tank Style	Horizontal



AVB3200

Tank Size	3,200 Gallons
Tank Style	Horizontal



ACCESSORIES



	PRODUCT CODE	TANK SIZE (GAL)	DIMENSIONS (DIAMETER X HEIGHT)	LID SIZE	FITTING SIZE
MIXING CONES					
1	THM030KWH01	30	20" x 45"	16"	2"
2	THM030AKWH01	30	24" x 42"	16"	2"
3	THM045KWH01	45	30" x 43"	16"	2"
4	THM060KWH01	60	30" x 45"	16"	2"



	PRODUCT CODE	COMPATIBLE TANKS (GALLONS)	MATERIAL
TANK LADDER			
1	AZFTLH01	1,000, 1,200, 1,400, 1,600, 1,900, 2,200, 2,500, 2,800, 3,000, 3,200, 3,500, 4,500	Steel
2	AZFTLH01EXT	Extension Needed For - 3,000 & 4,500	Steel

ACCESSORIES

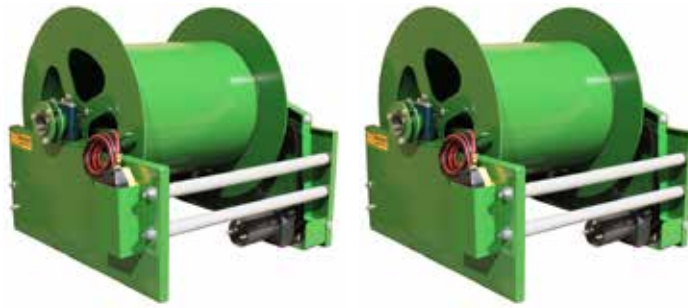

	PRODUCT CODE	DIMENSIONS (L X W X H)	HOSE LENGTH	HOSE DIAMETER	WEIGHT (LBS)
ELECTRIC REEL					
1	AHTSF002	29" x 31" x 27"	HOSE NOT INCLUDED	2" (Fits 60 feet)	150
2	AHTSF001	41" x 31" x 39"	HOSE NOT INCLUDED	3" (Fits 75 feet)	225



	PRODUCT CODE	DIAMETER	WEIGHT (LBS)	MATERIAL	AMOUNT NEEDED PER 100 GALLONS
BAFFLE BALLS					
1	AVB195	7.5"	0.25	Poly	50
2	AVB355	14"	0.8	Poly	10



PUMP ENGINE COVER	
Product Code	AVPC01
Dimensions	20"L x 15"W x 17"H
Material	Poly

SIGHT GAUGE (THREADED)	
Product Code	ATG01
Size	3/4"
Fits on: All THF & THD Series Fits on: THV & THC (1,000 - 3,100)	

SIGHT GAUGE (BOLTED)	
Product Code	ATG03
Size	3/4"
Fits on: THV & THC (3,200 - 10,000)	

PARTS



	PRODUCT CODE	MAX FLOW (GPM)	MAX PRESSURE (PSI)	MANUAL OR ELECTRIC START	MOTOR TYPE	PUMP TYPE	SEAL TYPE	HOSE CONNECTION SIZE
TRANSFER PUMPS								
1	CB200P6PRO	216	53	Manual	Briggs & Stratton® 6.5 HP	2" Banjo® Centrifugal Poly	EPDM	2" In/2" Out
2	CB200PH5	216	53	Manual	Honda® GX160 5.5 HP	2" Banjo® Centrifugal Poly	EPDM	2" In/2" Out
3	CB300PH6	293	35	Manual	Honda® GX200 6.5 HP	3" Banjo® Centrifugal Poly	EPDM	3" In/3" Out
4	CB222PIH5	205	43	Manual	Honda® GX160 5.5 HP	2" Banjo® Centrifugal Cast Iron	EPDM	2" In/2" Out



	PRODUCT CODE	DESCRIPTION
LIDS		
1	CFLS16HVCONVKIT	16" STAINLESS STEEL LID
2	CFLP16HV	16" HINGED - 3" VENTED LID
3	CA356060	16" HINGED, 2" VENTED LID
4	CA3511221	8" THREADED, VENTED LID
5	CVTL06	6" THREADED VENTED LID ONLY
6	CG839113021	4" THREADED VENTED LID ONLY



	PRODUCT CODE	DESCRIPTION
HOSE		
1	CLUPEB10009	2" REINFORCED FLEXIBLE SUCTION HOSE
2	CLUPEB08513	3" REINFORCED FLEXIBLE SUCTION HOSE
3	CLUESB020001	3/8" EPDM SPRAY HOSE 200 PSI
4	CLUESB020002	1/2" EPDM SPRAY HOSE 200 PSI
5	CLUESB020004	3/4" EPDM SPRAY HOSE 200 PSI
6	CLUVGC03504	3/4" CLEAR VINYL HOSE
7	CLUESB020005	1" EPDM SPRAY HOSE 200PSI

PARTS



VALVES



FITTINGS



SIPHON TUBES



BOLTED FITTINGS



STAINLESS FITTINGS

To access our large range of parts and accessories, visit your local Enduraplas dealer or browse our website.



www.enduraplasdealers.com



www.enduraplas.com

THE LEADER IN LIQUID MANAGEMENT



ABOVE GROUND TANKS



BELOW GROUND TANKS



TRAILERS



SPRAY EQUIPMENT



REFUELING EQUIPMENT



FIRE EQUIPMENT



WATER STORAGE TANKS

ENGINEERED FOR ENDURANCE®

COMPANY INFORMATION

WARRANTY

You can depend on your Enduraplas tanks and trailers to work as hard as you do, and for Enduraplas to stand behind its equipment. We now offer an industry leading warranty because we can.

	Standard Warranty	Extended Warranty
Tanks	5 Years	*10 Years
Trailer Frames	1 Year	-
Parts & Accessories	**1 Year	-

*Double your tank warranty by completing your warranty registration. Please contact your dealer for complete terms & conditions.

**Unless expressly stated that they have an extended original manufacturer warranty.

THE BRAND

The name Enduraplas® originated in 2003. Since then, the brand has spread quickly throughout USA and Canada to a point where it is a common name heard in the agriculture industry. Products with the Enduraplas® brand are recognized as high quality and premium in the markets we serve.

The following are registered (®) or unregistered (™) trademarks of Enduraplas LLC: Enduraplas®, Engineered for Endurance®, Pickup King™, STRONG-X™, RIBBED-WALL™, THICK-WALL™, ANCHOR-POINT™, SINGLE-PIECE™, AUTO-DRAIN™, LIFTING-LUGS™, PIN-MOUNT™, ANTI-SPLASH™.

LEGAL NOTICE

Enduraplas reserves the right to change specifications, design and price of the products described in this literature without notice. Images used in this literature are pictured for display purposes only. Warranty of all products is only applicable when the product is used in accord with the operator's manual. Improper use of any tank, trailer or accessory may cause serious or fatal injury. Read, understand and follow carefully the operator's manual before using these products.

FREIGHT

Contact your local dealer to learn the exact freight charges in your area. To find your closest dealer, visit EnduraplasDealers.com.

#EngineeredforEndurance

SHARE YOUR ENDURAPLAS SET-UP



CONTACT YOUR DEALER

Dealer Details Here:

Enduraplas®

113 1st Street
Neche, ND 58265
USA

2820 Farm to
Market 1516
Converse, TX 78109
USA

1 (877) 877-4370
Info@enduraplas.com

To find a dealer: enduraplasdealers.com
For product information: enduraplas.com



*All Enduraplas poly tanks are manufactured in the United States of America.